

Clarke® CONTRACTOR®



1200W VARIABLE SPEED ROUTER

MODEL NO: CR1200

PART NO: 6462083

OPERATION & MAINTENANCE INSTRUCTIONS

UK
CA | CE



ORIGINAL INSTRUCTIONS

DL0123 ISS4

INTRODUCTION

Thank you for purchasing this CLARKE 1200W Variable Speed Router.

The router is designed to be fitted with rotary cutters that allows you to cut slots into or shape the edges of various materials.

Before attempting to use this product, please read this manual thoroughly and follow the instructions carefully. In doing so you will ensure the safety of yourself and that of others around you, and you can look forward to your purchase giving you long and satisfactory service.

GUARANTEE

This product is guaranteed against faulty manufacture for a period of 12 months from the date of purchase. Please keep your receipt which will be required as proof of purchase.

This guarantee is invalid if the product is found to have been abused or tampered with in any way, or not used for the purpose for which it was intended.

Faulty goods should be returned to their place of purchase, no product can be returned to us without prior permission.

This guarantee does not effect your statutory rights.

IN THE BOX

- 1 x Router
- 1 x Parallel Fence
- 2 x Fence Rods c/w fixing screws
- 1 x Dust Extraction Port - Internal Ø : 35 mm
- 1 x Dust Extraction Reducer - Internal Ø : 32 mm
- 2 x C/S Head Screw - to retain Guide Bush & Extraction Adaptor
- 1 x Trammel Attachment c/w fixings
- 3 x Collets - 1 x 6 mm, 1 x 8 mm (fitted) 1 x 1/4" (6.35 mm)
- 1 x Collet Nut (fitted)
- 1 x Spanner
- 1 x Template Guide Bush - Internal Ø : 15 mm; External Ø ; 18 mm
- 1 x Reusable cable tie

GENERAL SAFETY RULES

1. WORK AREA

- a. **Keep the work area clean and well lit.** Cluttered and dark areas invite accidents.
- b. **Do not operate power tools in explosive atmospheres, such as in the presence of flammable liquids, gases or dust.** Power tools create sparks which may ignite the dust or fumes.
- c. **Keep children and bystanders away while operating a power tool.** Distractions can cause you to lose control.

2. ELECTRICAL SAFETY

- a. **Power tool plugs must match the outlet. Never modify the plug in any way. Do not use adapter plugs with earthed (grounded) power tools.** Unmodified plugs and matching outlets will reduce the risk of electric shock.
- b. **Do not expose power tools to rain or wet conditions.** Water entering a power tool will increase the risk of electric shock.
- c. **Do not abuse the cord. Never use the cord for carrying, pulling or unplugging the power tool. Keep the cord away from heat, oil, sharp edges or moving parts.** Damaged or entangled cords increase the risk of electric shock.
- d. **When operating a power tool outdoors, use an extension cord suitable for outdoor use.** Use of a cord suitable for outdoor use reduces the risk of electric shock.

3. PERSONAL SAFETY

- a. **Stay alert, watch what you are doing and use common sense when operating a power tool.** Do not use a power tool while you are tired or under the influence of drugs, alcohol or medication. A moment of inattention while operating power tools may result in personal injury.
- b. **Use safety equipment. Always wear eye protection.** Safety equipment such as dust mask, non-skid safety shoes, hard hat, or hearing protection used for appropriate conditions will reduce personal injuries.
- c. **Avoid accidental starting.** Ensure the switch is in the off position before plugging in. Carrying power tools with your finger on the switch or plugging in power tools that have the switch on invites accidents.
- d. **Remove any adjusting key or spanner before turning the power tool on.** A spanner or a key left attached to a rotating part of the power tool may result in personal injury.

- e. **Do not overreach.** Keep proper footing and balance at all times. This enables better control of the power tool in unexpected situations.
- f. **Dress properly.** Do not wear loose clothing or jewellery. Keep your hair, clothing and gloves away from moving parts. Loose clothes, jewellery or long hair can be caught in moving parts.
- g. **Hold power tool by insulated gripping surfaces, because the cutter may contact its own cord.** Cutting a "live" wire may make exposed metal parts of the power tool "live" and shock the operator.
- h. **Use clamps or another practical way to secure and support the workpiece to a stable platform.** Holding the work by your hand or against the body leaves it unstable and may lead to loss of control.

4. POWER TOOL USE AND CARE

- a. **Do not force the power tool.** Use the correct power tool for your application. The correct power tool will do the job better and safer at the rate which it was designed.
- b. **Do not use the power tool if the switch does not turn it on and off.** Any power tool that cannot be controlled with the switch is dangerous and must be repaired.
- c. **Disconnect the plug from the power source before making any adjustments, changing accessories, or storing power tools.** Such preventive safety measures reduce the risk of starting the power tool accidentally.
- d. **Store idle tools out of the reach of children and do not allow persons unfamiliar with the power tool or these instructions to operate the power tool.** Power tools are dangerous in the hands of untrained users.
- e. **Maintain power tools.** Check for misalignment or binding of moving parts, breakage of parts and any other condition that may affect the power tools operation. If damaged, have the power tool repaired before use. Many accidents are caused by poorly maintained power tools.
- f. **Keep cutting tools sharp and clean.** Well maintained cutting tools with sharp cutting edges are less likely to bind and are easier to control.
- g. **Use the power tool, accessories and tool bits etc., in accordance with these instructions.** Use of the power tool for operations different from intended could result in a hazardous situation.

5. SERVICE

- a. **Have your power tool serviced by a qualified repair person using only identical replacement parts.** This will ensure that the safety of the power tool is maintained.

ADDITIONAL WARNINGS FOR ROUTERS

- a. Do not start the router while the cutter is touching the workpiece.
- b. Make sure that the cutter has stopped before engaging the spindle lock. Do not touch the router cutters immediately after use - they can be very hot.
- c. Make sure that the plunge spring is always fitted when using hand-held.
- d. Only use router cutters designed for woodwork and suitable for the speed rating of this router.
- e. Only use cutters with a shank diameter exactly matched to the collet(s) supplied with this router.
- f. Extra precautions must be taken when using cutters with a diameter greater than 2" (50mm). Use very slow feed rates and/or multiple shallow cuts to prevent the motor from overloading.
- g. Remove the plug from the socket before carrying out any adjustment, servicing or maintenance.
- h. When an extension cable is required, you must make sure that it has the right ampere rating for your power tool and is in a safe electrical condition.
- i. Always examine walls, floors and ceilings for hidden power cables and pipes.
- j. After long working periods external metal parts and accessories can be hot.
- k. Handle router cutters carefully, they can be extremely sharp.
- l. Examine the cutter carefully for signs of damage or cracks before use. Replace damaged or cracked cutters immediately.
- m. Always use both handles and make sure that you have a firm grip on the router before starting work.
- n. Keep your hands away from the cutter.
- o. Before using the tool to make a cut, switch on and let it run for a while. Look for vibration or wobbling that could indicate an improperly installed cutter.
- p. Take notice of the direction of rotation of the cutter and the direction of feed.
- q. Always switch off and wait until the cutter has stopped before removing the router from the work piece and also before putting the router down on the workbench.
- r. Make sure that you have removed foreign objects such as nails and screws from the work before starting.

ELECTRICAL CONNECTIONS



WARNING: READ THESE ELECTRICAL SAFETY INSTRUCTIONS THOROUGHLY BEFORE CONNECTING THE PRODUCT TO THE MAINS SUPPLY.

Before switching the product on, make sure that the voltage of your electricity supply is the same as that indicated on the rating plate. This product is designed to operate on 230VAC 50Hz. Connecting it to any other power source may cause damage.

This product may be fitted with a non-rewireable plug. If it is necessary to change the fuse in the plug, the fuse cover must be refitted. If the fuse cover becomes lost or damaged, the plug must not be used until a suitable replacement is obtained.

If the plug has to be changed because it is not suitable for your socket, or due to damage, it should be cut off and a replacement fitted, following the wiring instructions shown below. The old plug must be disposed of safely, as insertion into a mains socket could cause an electrical hazard.

If the colours of the wires in the power cable of this product do not correspond with the markings on the terminals of your plug, proceed as follows.

- The wire which is coloured **Blue** must be connected to the terminal which is marked **N** or coloured **Black**.
- The wire which is coloured **Brown** must be connected to the terminal which is marked **L** or coloured **Red**.

Plug must be BS1363/A approved.

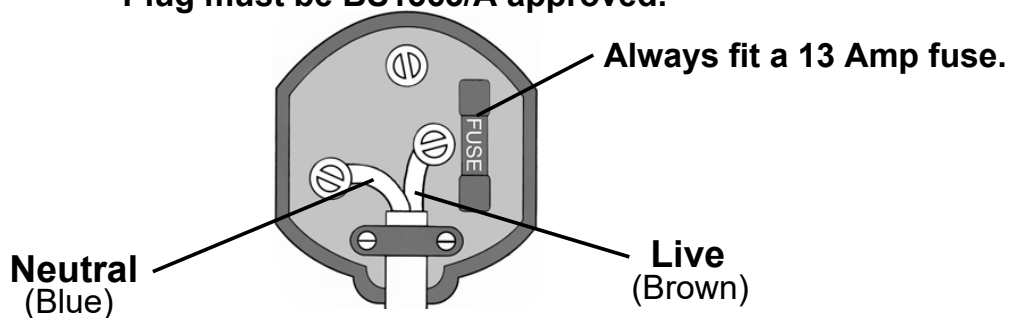

Ensure that the outer sheath of the cable is firmly held by the clamp

We strongly recommend that this machine is connected to the mains supply via a Residual Current Device (RCD)



This symbol indicates that this is a Class II product, and does not require an earth connection.

OVERVIEW



	DESCRIPTION		DESCRIPTION
1	Collet nut	10	Dust Extractor Port
2	Spindle Lock	11	Side fence locks
3	Mains Lead	12	Guide Rod
4	Handle	13	Template Guide Bush
5	Fine Height Adjuster	14	Spanner
6	Depth Stop Scale	15	Trammel Attachment
7	Depth Stop Lock	16	Dust Port Reducer
8	Depth Stop Turret	17	Screws
9	Side Fence		

BEFORE USE

INSTALLING AND REMOVING A ROUTER CUTTER



WARNING: MAKE SURE THAT THE ROUTER IS ISOLATED FROM POWER SUPPLY BEFORE YOU CHANGE THE ROUTER CUTTERS.

WARNING: MAKE SURE THAT YOU USE THE RIGHT SIZE COLLET FOR THE ROUTER CUTTER BEING USED.

WARNING: ONLY USE ROUTER CUTTERS THAT HAVE A SPEED RATING THAT EXCEEDS THE MAXIMUM SPEED OF THIS ROUTER.

1. Push and hold the spindle lock.
2. Turn the spindle until the spindle locks into position.
3. Use the spanner supplied to loosen the collet nut and remove the router cutter if one is installed.
4. Put a router cutter into the spindle and tighten collet nut.

NOTE: At least 3/4 of the shank must be put in the collet.

NOTE: Do not tighten the collet nut without a router cutter installed

5. Release spindle lock.

CHANGE THE COLLET SIZE

1. Push and hold the spindle lock.
2. Turn the spindle until it locks into position.
3. Loosen the collet nut using the spanner supplied.
4. Carefully remove the collet from the nut and replace with the collet you need.
 - Your router is supplied with 3 collets 1/4", 6 mm and 8 mm.
5. Replace the nut.

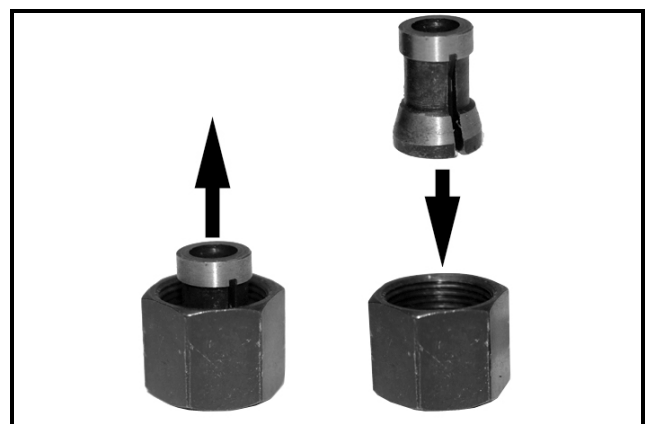
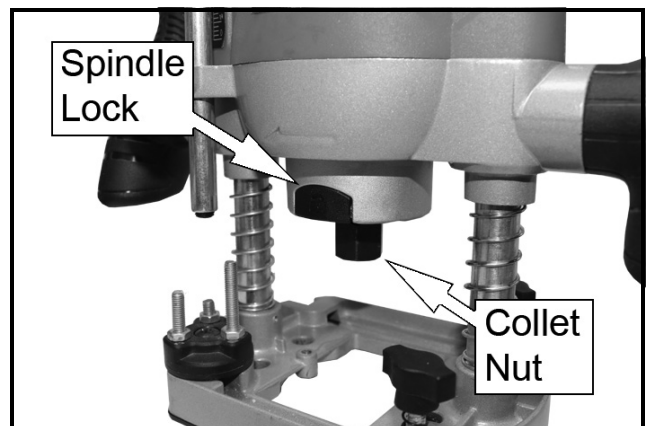

INSTALL AND REMOVE THE DUST EXTRACTION PORT

1. If required, place the nuts supplied in to sockets on the dust extraction port as shown.
2. Fit the dust extraction port to the router as shown using the screws supplied
 - The dust extraction port has an internal diameter of 35 mm.
3. Add the reducer adaptor if required.
 - The reducer has an internal diameter of 32 mm.

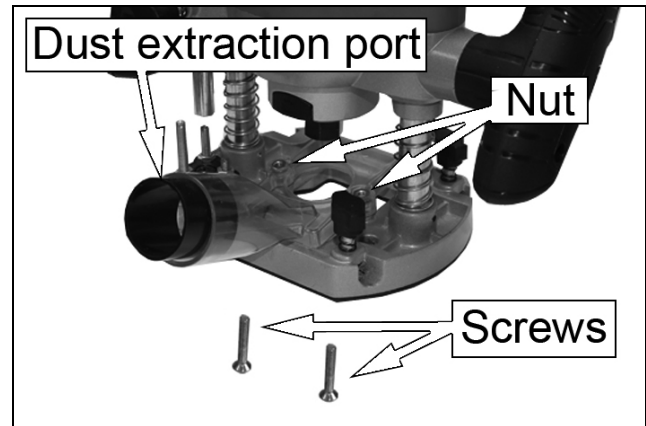

OPERATION

CORRECT HAND POSITION

The correct way to hold the router is as shown.



SWITCHING ON/OFF

1. Grip the router with two hands, making sure that the handle with the trigger is in the right hand.
2. Push and hold the safety button, and squeeze the trigger.
 - Let the motor reach full speed before use.
 - To stop the router, release the trigger.

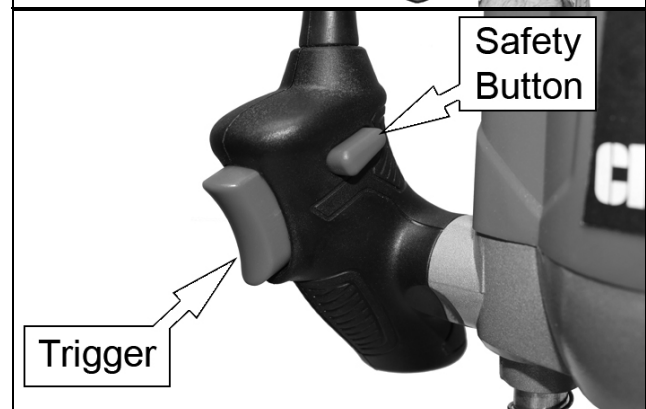

WARNING: THE CUTTER WILL CONTINUE TO TURN FOR SEVERAL SECONDS AFTER THE TRIGGER IS RELEASED.

ADJUSTING THE DEPTH OF CUT.



CAUTION: TO PREVENT DAMAGE TO THE MOTOR OR DIFFICULTY CONTROLLING THE TOOL, THE DEPTH OF CUT SHOULD BE LIMITED TO 5-6 MM IN EACH PASS. IF YOU REQUIRE MORE THAN THIS MAKE MULTIPLE CUTS WITH GRADUALLY DEEPER SETTINGS.

1. Install the cutter into the router and put the router on a flat surface.
2. Release the plunge lock lever and lower the router body until the cutter just touches the surface, then apply the plunge lock to lock the router in position.

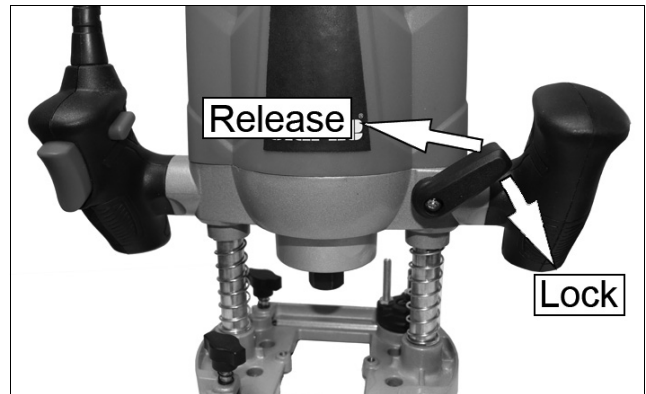

3. Slacken the depth stop lock and lower the depth stop until the rod touches the turret at its lowest setting.
 - Rotate the turret if needed.
4. Raise the height of the depth stop by the depth you want to cut into the workpiece.
 - The scale is marked in mm.
5. Tighten the depth stop lock.

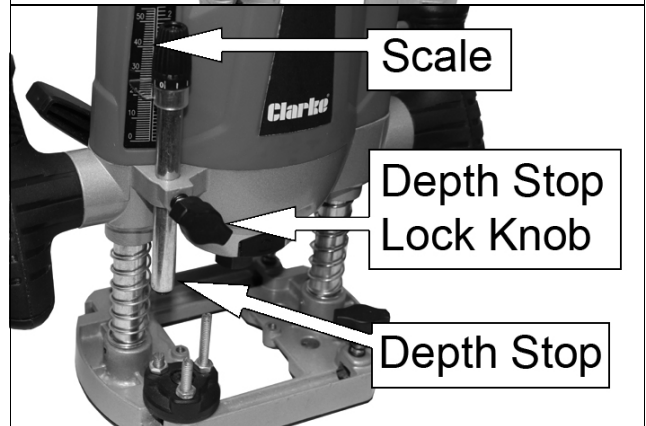

USING THE FINE HEIGHT ADJUSTER

1. Make the fine adjustments by turning the fine height adjuster.
2. Make sure that the pointer is resting against the bottom of the fine height adjuster. If not slide it up until it touches.



USING THE MULTI-STOP TURRET

The multi-stop turret can be used to assist in making multiple passes. Using the turret in this manner removes the necessity for resetting the depth stop for each pass. Each stop on the turret is approximately 3mm.

1. With the total depth set and the router raised fully, turn the turret to it's highest position.
2. Make the first pass on the wood.
3. Rotate the turret to a lower setting and make the second pass.
4. Repeat this until the final cut is made.

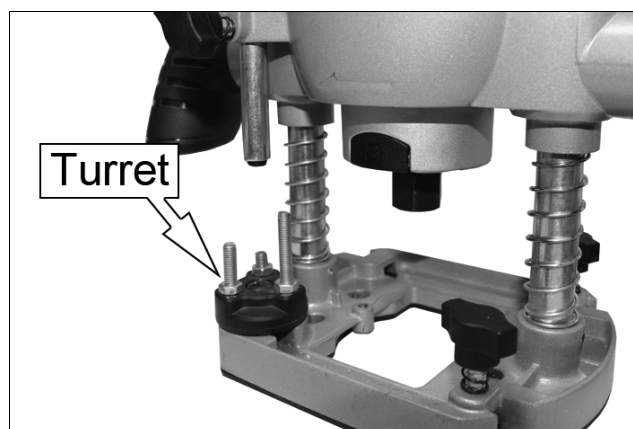

CHANGING THE SPINDLE SPEED

The router speed is infinitely variable from 11000 to 30000 rpm

1. Turn the Speed control to the required setting.
 - Generally, the larger the diameter of the cutter, the slower the tool speed should be.
 - The correct setting will also depend on the density of the material being cut, the feed speed and the depth of cut.
2. It is advisable to make practice cuts on a piece of scrap timber to determine the best speed as a dramatic loss of RPM will overload the motor.



FEED DIRECTION

Remember that the direction the cutter is fed into the wood must always be against the direction of rotation as shown in the diagram on the right.

This ensures a quality finish and also ensures that the cutting action pulls the router into the wood.

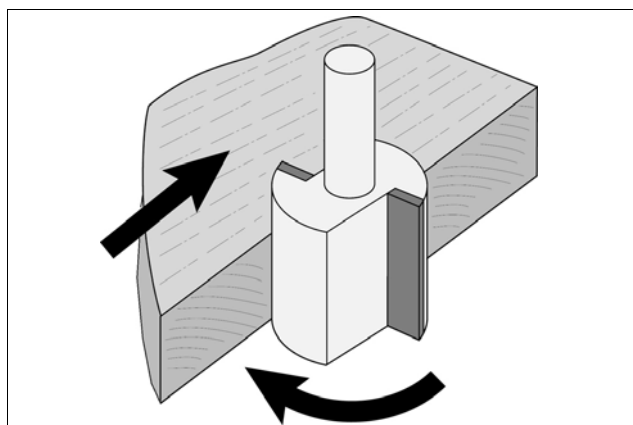

FEED SPEED

The speed at which the router is moved along the workpiece must not be so fast that it causes the motor to slow down, or too slow that the cutter starts to leave burn marks on the timber.

The proper feed rate to use depends on the cutter size, the material being cut, the depth of the cut and the speed selected.

Practice judging the feed speed on scrap timber by listening to the router during use.

MOULDING NATURAL TIMBERS

Always route the end grain of natural timber first. This will ensure that any breakout is removed when the long grain is routed.

PLUNGE CUTTING

1. Set the required depth of cut, See page 10.
2. With the motor running, press down on the two handles to plunge the cutter into the wood.
3. Depress the plunge locking lever to lock the motor carriage in position.
4. Carry out the routing operation.
5. Release the plunge locking lever to return the motor carriage to its normal position.

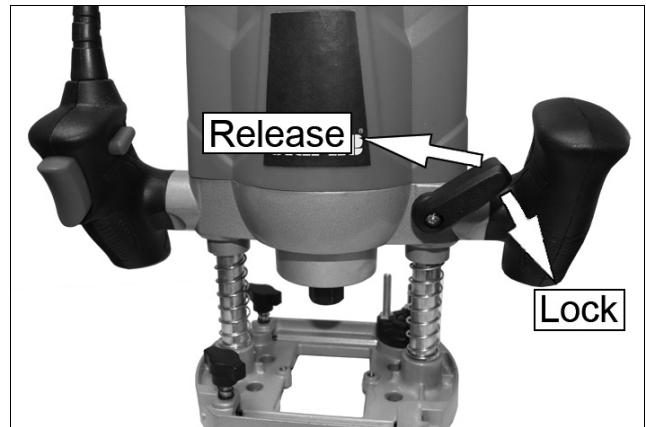

SIDE FENCE ROUTING

The side-fence is used to guide the router when routing grooves and slots parallel to the workpiece edge.

- The edge of the workpiece must be straight and true.

FITTING THE SIDE FENCE

1. Fit the guide rods to the side fence and secure using the screws, washers and spring washers supplied.
2. Make sure that the side fence locks are fully loosened.
3. Slide the guide rods into the router base.
4. Tighten the Side fence locks.

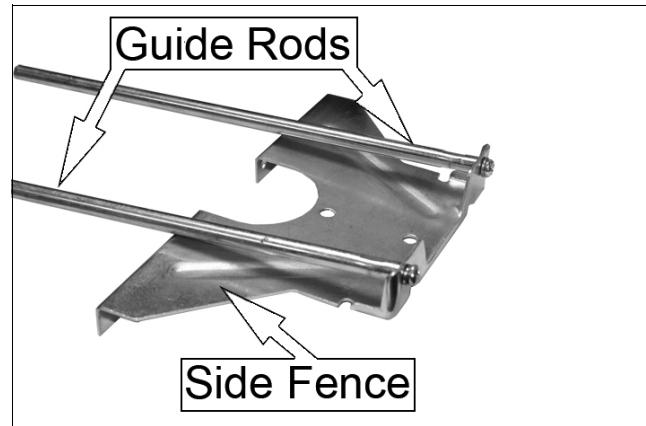

USING THE SIDE FENCE

1. Adjust the side-fence as required and lock in place using the side fence locks.
2. Set the depth of cut, See page 10.
3. When the router reaches full speed, gently lower the cutter into the workpiece and lock the plunge lever.
4. Move the router along the workpiece, maintaining a sideways pressure to ensure the side fence does not come away from the workpiece and downward pressure on the inside hand to prevent the router from tipping over.

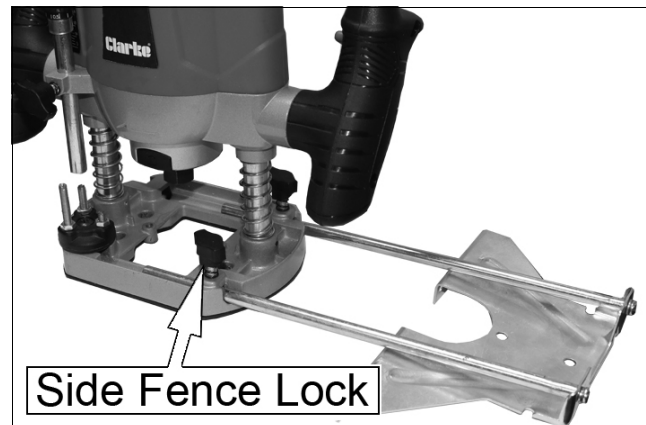

NOTE: When starting the cut, increase the pressure slightly on the front of the side fence and as you reach the end of the workpiece increase the pressure on the rear half on the side fence, this will prevent the router cutter from 'snatching' around the workpiece

5. When finished, release the plunge lever to raise the router, and switch off.

ROUTING WITH TEMPLATES

FITTING THE TEMPLATE GUIDE BUSH

The template guide bush shares the same screws that are used when connecting the dust extraction port.

1. If fitted, remove the screws that hold on the dust extraction port.
2. Place the template guide bush into position as shown.
3. Replace the screws.

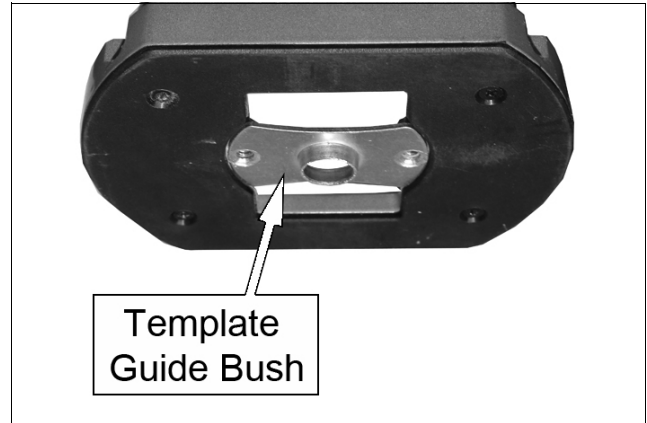

MAKING A TEMPLATE

Router templates must have a minimum thickness of 6mm and can be home made or shop bought.

When making templates, you must remember to allow for the distance from the edge of the guide bush to the edge of the cutter, this is known as the offset.

CALCULATIONS FOR THE TEMPLATE OFFSET

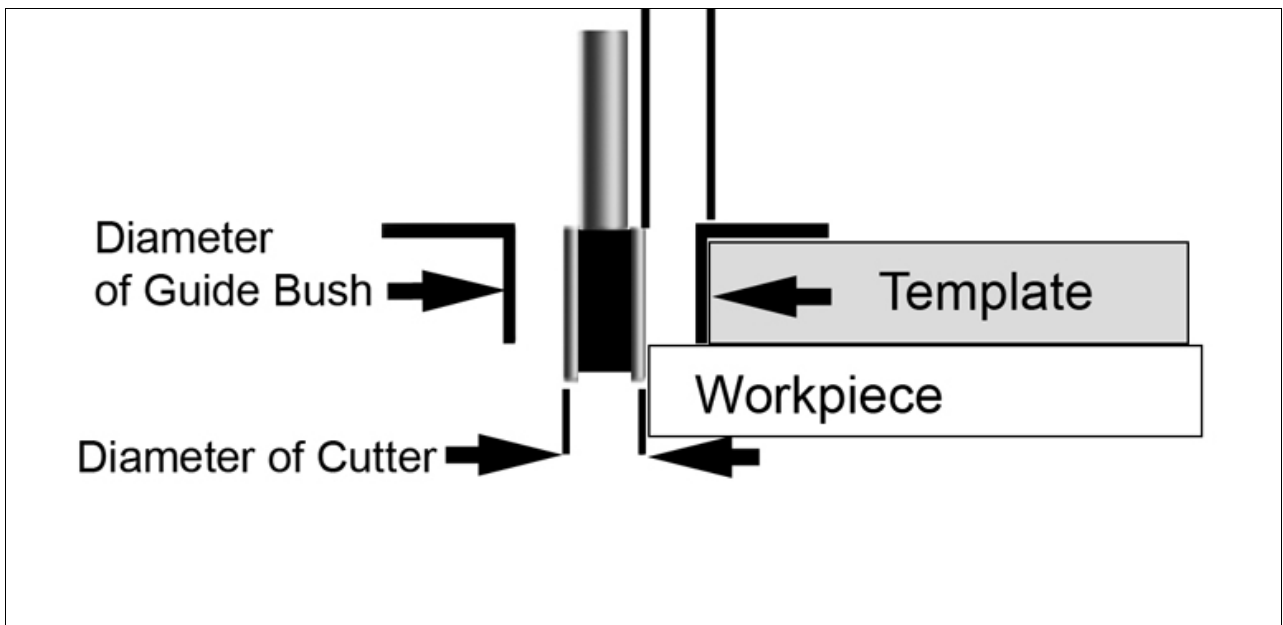

The offset is calculated in the following way.

(The outer diameter of the guide bush minus (-) the diameter of the cutter) divided by (/) 2.

For example if you use the supplied 18 mm guide bush and a 12mm router cutter the offset would be 3 mm.

FITTING YOUR ROUTER TO A ROUTER TABLE

A router table allows the work to be passed over the router, rather than passing the router over the work. This makes working with smaller objects easier. A router table may be fitted with a fence, fingerboards and other work-guiding accessories to make the operation safer and more accurate.

- We recommend the Clarke CRT1 available from your local Clarke dealer.
1. With the router unplugged, fit the router to the router table as shown in the router table user guide.
 2. Push and hold the safety button, and pull the trigger switch on the router.
 3. Lock the trigger switch in the ON position using the re-useable cable tie supplied.

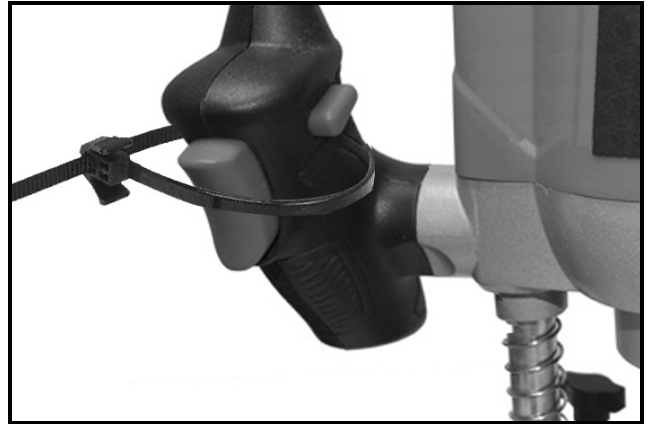

CAUTION: ONLY USE THE CABLE TIE IF THE ROUTER IS FITTED TO THE ROUTER TABLE.

4. Plug the router into the router table switch and follow the instructions in the router table user guide.



MAINTENANCE AND CARE

CLEANING

- To ensure the best performance from the router, it must be kept clean.
- Keep the cooling vents on the motor housing clean and unobstructed at all times. Blow out any dust and dirt at regular intervals.

GENERAL MAINTENANCE

- Make sure that all nuts, bolts and screws are tight and secure.
- Always have any damaged or worn parts repaired or replaced.
- Always have your router repaired by qualified service personnel. Do not attempt to repair the router unless you are qualified to do so.

STORAGE

- Make sure that the router has been thoroughly cleaned before storing it in a clean, dry place out of the reach of children.

LUBRICATION

- The bearings of the machine do not need lubrication, as they are sealed for life.

ENVIRONMENTAL PROTECTION



Do not dispose of this product with general household waste. All tools, accessories and packaging should be sorted, taken to a recycling centre and disposed of according to the laws governing Waste Electrical and Electronic Equipment.

TROUBLESHOOTING

Problem	Reason	Solution
Router is overheating.	Ventilation holes are blocked / Machine is dirty.	Make sure the ventilation holes are clear.
	Router is overloaded.	Do not use put excessive pressure on the cutter.
Router will not operate.	No supply of power	Check that power is available at source
	Brushes worn or sticking	Contact the CLARKE service department (0208 988 7400)
	Switch is faulty	Contact the CLARKE service department (0208 988 7400)
	Motor components open or short circuited	Contact the CLARKE service department (0208 988 7400)
Router runs slowly.	Blunt or damaged cutter	Re-sharpen or replace cutter
	Variable speed set low	Increase variable speed setting.
	Motor is overloaded	Reduce pressure on router.
Makes an unusual sound.	Mechanical obstruction	Contact the CLARKE service department (0208 988 7400)
	Armature has shorted sections	Contact the CLARKE service department (0208 988 7400)
Excessive vibration.	Bent cutter shank	Replace cutter
Heavy sparking occurs inside motor housing.	Brushes not moving freely	Disconnect power, remove brushes, clean or replace
	Armature short circuited or open circuited	Contact the CLARKE service department (0208 988 7400)
	Commutator dirty	Contact the CLARKE service department (0208 988 7400)
Micro adjuster "clicks"	Plunge lock engaged	Release plunge lock lever
	Reached end of adjustment	Reset the router.

SPECIFICATIONS

Electric Supply	230V 50Hz
Motor Power Rating	1200W
No Load Speed	11000 - 30000 RPM ($\pm 10\%$)
Plunge Range	0 - 55 mm
Collet Size	1 x 6 mm 1 x 8 mm (fitted) 1 x 1/4" (6.35 mm)
Dust extraction Adaptor Port Size	I/D 35 mm (with reducer 32mm)
Dimensions: (Length x Height x Width)	177 x 260 x 258 mm
Net Weight	2.8 kg
Sound Pressure level: dB LpA	84.7 dB
Sound Power level: dB LWA	95.7 dB + 3 dBA
Vibration Levels	6.4 m/s ² Uncertainty value K (1.5)

Specifications are correct at the time of going to print. CLARKE International reserve the right to change specifications at any time without prior notice.

VIBRATION EMISSIONS

The vibration values given in this manual have been measured in accordance to EN 60745.



WARNING: THE DECLARED VIBRATION EMISSION LEVEL REPRESENTS THE MAIN APPLICATION OF THE TOOL. IF THE TOOL IS USED FOR OTHER PURPOSES, POORLY MAINTAINED OR USED WITH OTHER ACCESSORIES, THE LEVELS MAY DIFFER.

The health risk depends upon the vibration level and the length of time of exposure to it.....in effect, a daily vibration dose.

Model Number	CR1200
Description	Router
Declared vibration emission value in accordance with	EN60745
Measured vibration emission value - a :	6.4 m/s ²
Uncertainty Value - k .	1.5

Additional safety measures to protect the user from the effects of vibration such as organization of work patterns and keeping your hands warm.

DECLARATION OF CONFORMITY



Hemmell Street, Epping, Essex CM16 4LG

DECLARATION OF CONFORMITY

This is an important document and should be retained.

We hereby declare that this product(s) complies with the following statutory requirement(s):

Electromagnetic Compatibility Regulations 2016
Supply of Machinery (Safety) Regulations 2008
The Restriction of the Use of Certain Hazardous Substances in Electrical and Electronic Equipment Regulations 2012

The following standards have been applied to the product(s):

EN IEC 55014-1:2021, EN IEC 55014-2:2021, EN IEC 61000-3-2:2019+A1,
EN IEC 61000-3-3:2013+A1, EN 62841-1:2015, EN 62841-2-17:2017, EN IEC 62321-3-1:2013,
EN IEC 62321-7-1:2015, EN IEC 62321-6:2015, EN IEC 62321-7-2:2017, EN ISO 17075-1:2017,
EN IEC 62321-8:2017.

The technical documentation required to demonstrate that the product(s) meet(s) the requirement(s) of the aforementioned legislation has been compiled and is available for inspection by the relevant enforcement authorities.

The UKCA mark was first applied in: 2023

Product Description: 230V Router
Model number(s): CR1200
Serial / batch Number: N/A
Date of issue: 04/01/2023

Signed:

J.A. Clarke
Director



Fitzwilliam Hall, Fitzwilliam Place, Dublin 2

DECLARATION OF CONFORMITY

This is an important document and should be retained.

We hereby declare that this product(s) complies with the following directive(s):

2014/30/EU *Electromagnetic Compatibility Directive*
2006/42/EC *Machinery Directive*
2011/65/EU *Restriction of the Use of Certain Hazardous Substances in Electrical & Electronic Equipment (RoHS) Directive*

The following standards have been applied to the product(s):

EN IEC 55014-1:2021, EN IEC 55014-2:2021, EN IEC 61000-3-2:2019+A1,
EN IEC 61000-3-3:2013+A1, EN 62841-1:2015, EN 62841-2-17:2017, EN IEC 62321-3-1:2013,
EN IEC 62321-7-1:2015, EN IEC 62321-6:2015, EN IEC 62321-7-2:2017, EN ISO 17075-1:2017,
EN IEC 62321-8:2017.

The technical documentation required to demonstrate that the product(s) meet(s) the requirement(s) of the aforementioned directive(s) has been compiled and is available for inspection by the relevant enforcement authorities.

The CE mark was first applied in: 2017

Product Description: 230V Router
Model number(s): CR1200
Serial / batch Number: N/A
Date of issue: 04/01/2023

Signed:

J.A. Clarke
Director

A SELECTION FROM THE VAST RANGE OF

Clarke®

QUALITY PRODUCTS



AIR COMPRESSORS
From DIY to industrial, Plus air tools, spray guns and accessories.

GENERATORS
Prime duty or emergency standby for business, home and leisure.

POWER WASHERS
Hot and cold, electric and engine driven - we have what you need

WELDERS

Mig, Arc, Tig and Spot.
From DIY to auto/industrial.

METALWORKING
Drills, grinders and saws for DIY and professional use.

WOODWORKING
Saws, sanders, lathes, mortisers and dust extraction.

HYDRAULICS
Cranes, body repair kits, transmission jacks for all types of workshop use.

WATER PUMPS
Submersible, electric and engine driven for DIY, agriculture and industry.

POWERTOOLS
Angle grinders, cordless drill sets, saws and sanders.

STARTERS/CHARGERS
All sizes for car and commercial use.



PARTS & SERVICE: 0208 988 7400

Parts Enquiries
Parts@clarkeinternational.com

Servicing & Technical Enquiries
Service@clarkeinternational.com

SALES: UK 01992 565333 or Export 00 44 (0)1992 565335

Clarke INTERNATIONAL Hemnall Street, Epping, Essex CM16 4LG
www.clarkeinternational.com